

It's voting time. Circle the name you choose under each category.

President - must be a River Bend **Gun Club** member

Cassalong Hopity

write in _____

Territorial Governor - must be a Life SASS member and a Rough Rider Cowboy Club member

Mean Matt McCord

Witch Doctor

write in _____

Buffalo Spirit Award - goes to the person you think put the most time and effort into make the Rough Riders successful this year. Yes - we know everyone on this list deserves to win - pick one.

Done Gone

Jake Dunson

J.B. Gunnison

Pig Iron Lane

Witch Doctor

write in _____

Do you have any suggestions for the incoming president? How would you like to see us improve the matches at River Bend?

Stage 1 Bay 2 Saloon

Rio Bravo Match by Jake Dunson and Witch Doctor

Round count

10 pistol

10 rifle

4 + shotgun on your person

Shooting Order

pistol

pistol

rifle

shotgun

Staging: 2 pistols loaded 5 rounds each and holstered
rifle loaded 10 rounds, staged on window tray
shotgun open, empty, on table on the porch

Stumpy is throwing TNT at the Burdett warehouse and John T. is shooting it.

Procedure: Start, standing with both hands touching saloon door. When ready, nod your head. Timer will ask you, "What would you do without me?" Shooter replies, **"I'd throw them myself."** At the beep, shoot pistol targets in a progressive sweep (1 on 1, 2 on 2, 3 on 3, 4 on 4) from either direction. Holster, move to window, and shoot rifle targets in a progressive sweep from either direction. Put open, empty rifle down and move to shotgun on porch. Shoot shotgun targets in any order, clays are a 5 second bonus each.

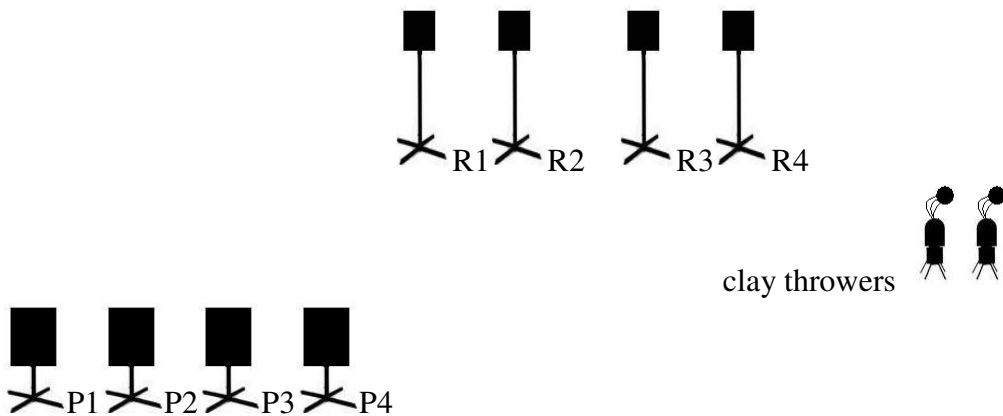

Stage 2 Bay 3

Rio Bravo Match by Jake Dunson and Witch Doctor

Round count

10 pistol
10 rifle
4 + shotgun on your person

Shooting Order

pistol
pistol
rifle
Shotgun

Staging

Rifle and Shotgun staged on table. Two pistols loaded with five rounds each and holstered.

John T. Chance: You want that gun, pick it up. I wish you would.

Procedure

Shooter starts standing with one foot on starting block, arms crossed across the chest. Shooter indicates ready by saying the line **“You want that gun - pick it up”** At the beep, shoot the pistol targets in a triple tap sweep from the right - put the 10th shot on the center target. Holster and with rifle triple tap rifle targets starting on the right - put the 10th shot on the center target. Return open and empty rifle to the table. Take shotgun. Shoot the 4 shotgun targets in a sweep starting on the right. Shotgun misses may be made up when they are made, or at the end of the sweep.

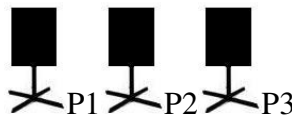
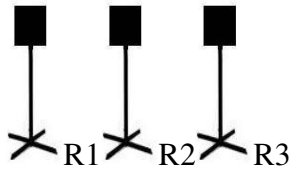

Stage 3 Bay 4 Fort

Rio Bravo Match by Jake Dunson and Witch Doctor

Round count

10 pistol
10 rifle
4 + shotgun on your person

Shooting Order

shotgun
pistol
rifle
Pistol

Staging: 2 pistols loaded 5 rounds each and holstered
rifle loaded 10 rounds, placed on left window
shotgun held at port arms

Sheriff John T. Chance is about to make his nightly rounds.

Procedure: Start at right window, shot gun held in both hands. When ready, say the line, **“If you don’t come back, Joe and me will have a nice long cry.”** At the beep, shoot shotgun targets in any order. Place open empty shotgun on window ledge and move to doorway. Shoot first pistol in a Nevada sweep from either direction through the doorway. Holster. Move to left window and Nevada sweep rifle targets from either direction. Return to (anywhere within) doorway and shoot second pistol in a Nevada sweep from either direction.

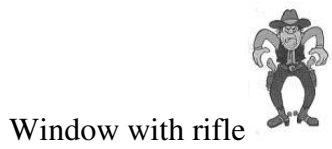
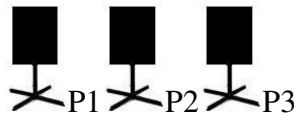
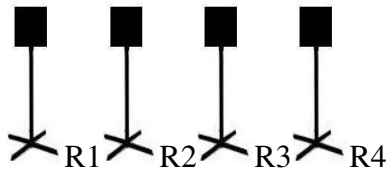

doorway+++++

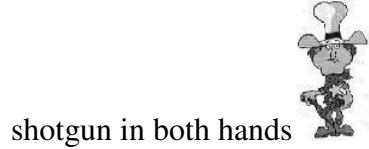

Stage 4 Bay 5 Jail

Rio Bravo Match by Jake Dunson and Witch Doctor

Round count

10 pistol
10 rifle
4 + shotgun on your person

Shooting Order

shotgun
rifle
pistol
pistol

Staging: 2 pistols loaded 5 rounds each and holstered
rifle loaded 10 rounds placed on target box
shotgun open, empty, held at port arms

John T. yells to Stumpy he's coming into the jail.

Procedure: Start, standing behind line in doorway, shotgun held in both hands. When ready, say the line, **"I'm coming in Stumpy."** At the beep, move to the target box or back doorway. Shoot shotgun targets in a sweep from either direction. Make up misses at any time. Place open, empty shotgun on target box. Shoot rifle targets 2, 1, 2 from either direction, then repeat as the first sweep. Place open, empty rifle on target box. Move to window. Shoot pistol targets 2, 1, 2 from either direction; repeat exactly with second pistol.

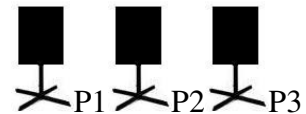
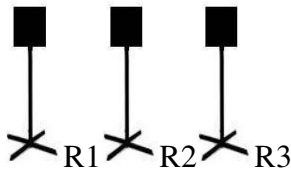

Shooter starts in front of the jail

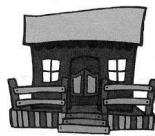

Stage 5 Bay 6 Cemetery

Rio Bravo Match by Jake Dunson and Witch Doctor

Round count

10 pistol

10 rifle

2 + shotgun on your person

Shooting Order

rifle

pistol

pistol

Shotgun

Staging

Shotgun staged on table. Rifle at port arms. Two pistols loaded with five rounds each and holstered.

John T. Chance: [*Referring to Colorado*] It's nice to see a smart kid for a change.

Stumpy: Yeah, he ain't like the usual kid with a gun.

Dude: Wonder if he's as good as Wheeler said?

John T. Chance: I'd say he is. I'd say he's so good, he doesn't feel he has to prove it.

Procedure

We need to sort out friend from foe. Shooter starts with rifle at port arms with at least one foot on starting mark. Shooter indicates ready by saying line **“He doesn’t feel the need to prove it”** At the beep, engage the buzzard targets in a continuous Nevada sweep from either direction with the rifle. Move and safely place open and empty rifle on the table. With pistols engage the rectangle targets in a continuous Nevada sweep from either direction. Holster and shoot shotgun knockdowns from either direction.

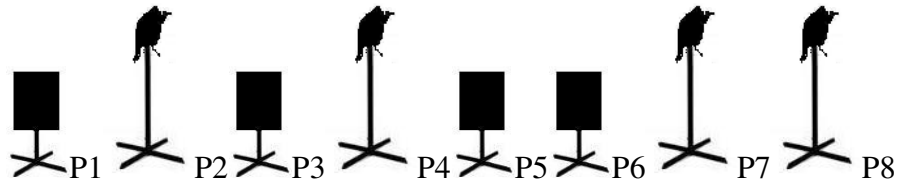

②



① position

Stage 6 Bay 7 Livery Stable

Rio Bravo Match by Jake Dunson and Witch Doctor

Round count

- 10 pistol
- 10 rifle
- 4 + shotgun on your person

Shooting Order

- rifle
- pistol
- pistol
- Shotgun

Staging: 2 pistols loaded 5 rounds each, holstered
 rifle loaded 10 rounds, held at port arms in left window
 shotgun open, empty in right window

Sheriff John T. Chance and Deputy Colorado are about to open fire on the Burdett warehouse.

Procedure: Start, standing in left window, rifle at port arms. When ready, say the line, **“Let’s make some music, Colorado.”** At the beep, shoot rifle targets 10 on 4, placing at least two rounds on each target. Place open, empty rifle in window. Move to door way and shoot pistol targets 5 on 4 with at least one shot from each pistol on each target. Holster, move to right window, and sweep shot gun targets from either direction. Misses may be made up at any time.

